

PrimeLine™ Syringe Pumps

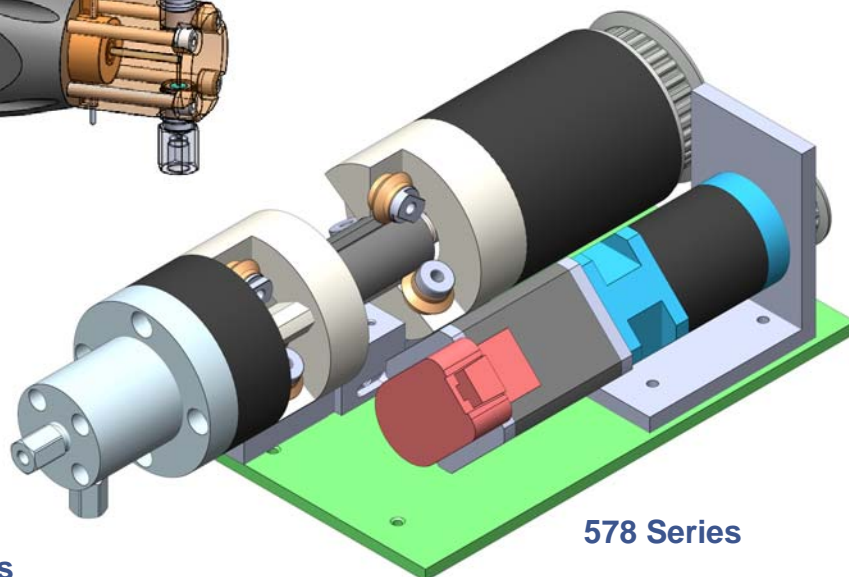
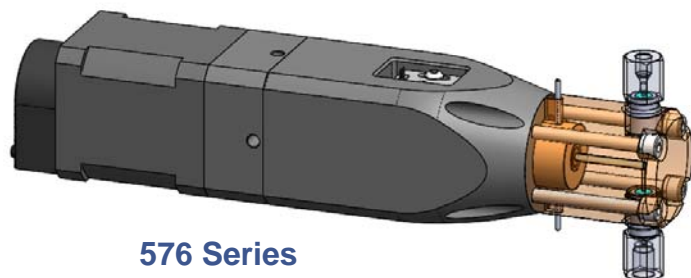

Features

- OEM private label for OEMs
- Spring loaded check valves allow operation in horizontal or vertical mounting orientation
- Graphical user interface
- Wash seal option for pumping buffers
- Stepper motor with drive/controller
- Available with HPLC (576 Series) & UHPLC (578 Series)
- Material options including Ultem, PEEK, Teflon or 316SS
- Modbus RTU, RS485 serial communications protocol for OEM software control
- Dual syringe HPLC & UHPLC gradient option
- Nano check valves eliminate need for expensive rotary switching valves. No particulates from worn valves!

ASI Model 576 Syringe Pumps outperformed competitors in head-to-head engineering trials. Flow precision, was closed as the critical evaluation metric by an independent engineering team. ASI was best-in-class for low flow ($\mu\text{L}/\text{min}.$) for pressures up to 9,000 PSI. Applications requiring such high precision includes: HPLC, LCMS, Sampling systems, Metering liquids and Sample preparation.

Unmatched flow precision at high pressure make the ASI 576 Syringe Pump the top choice for design engineers.

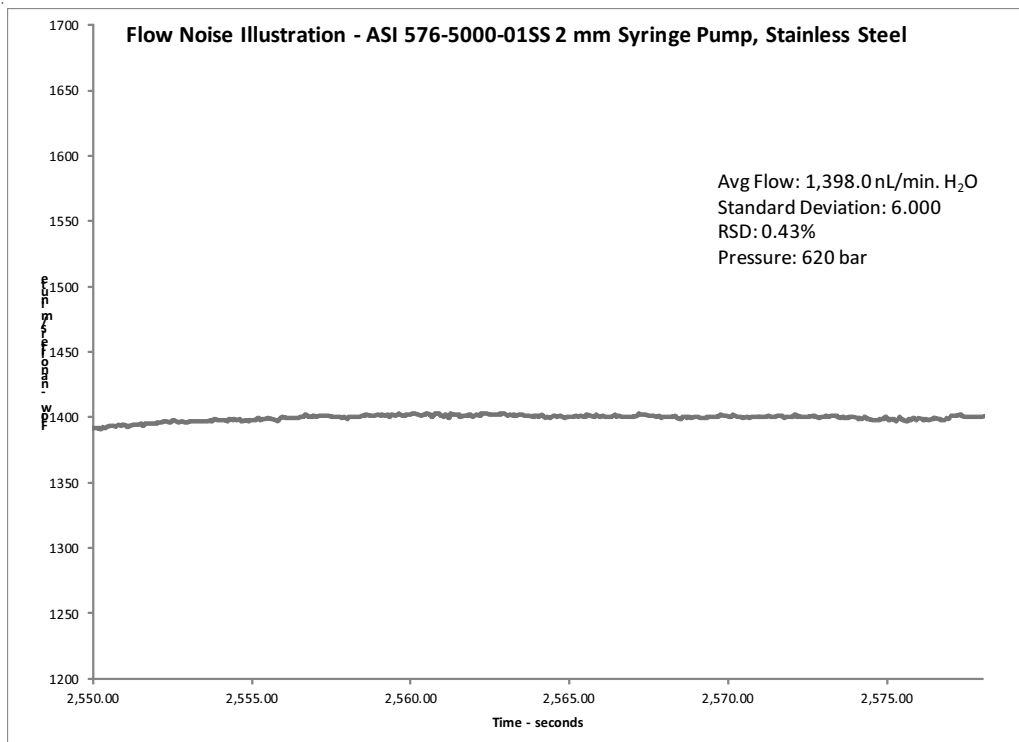
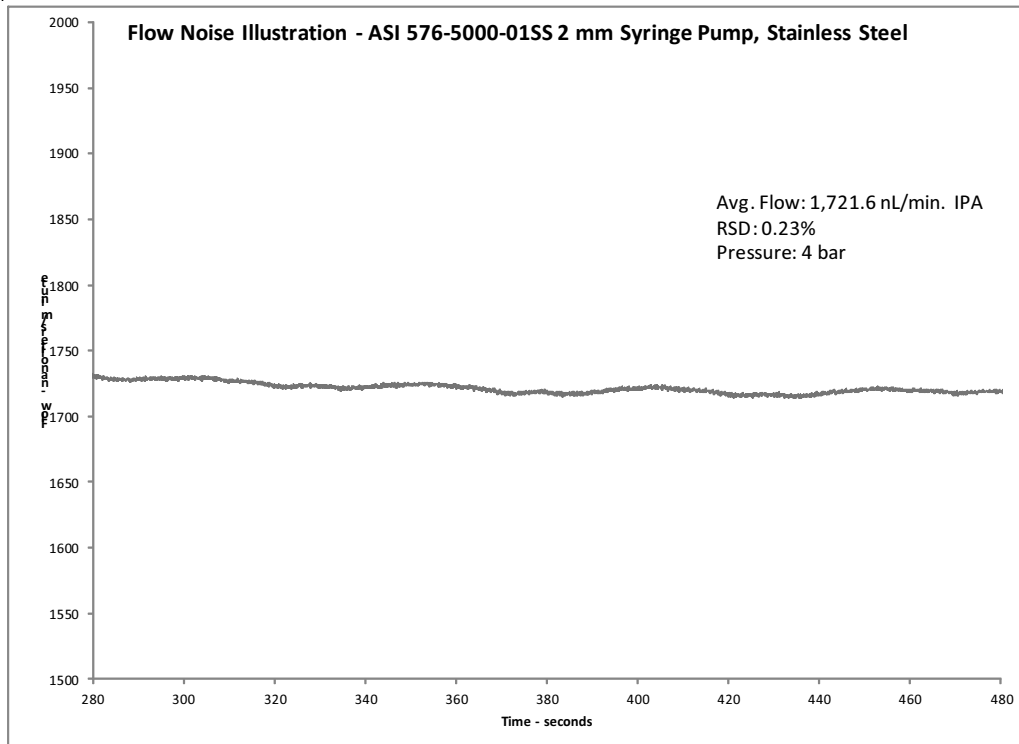

Competitor #1

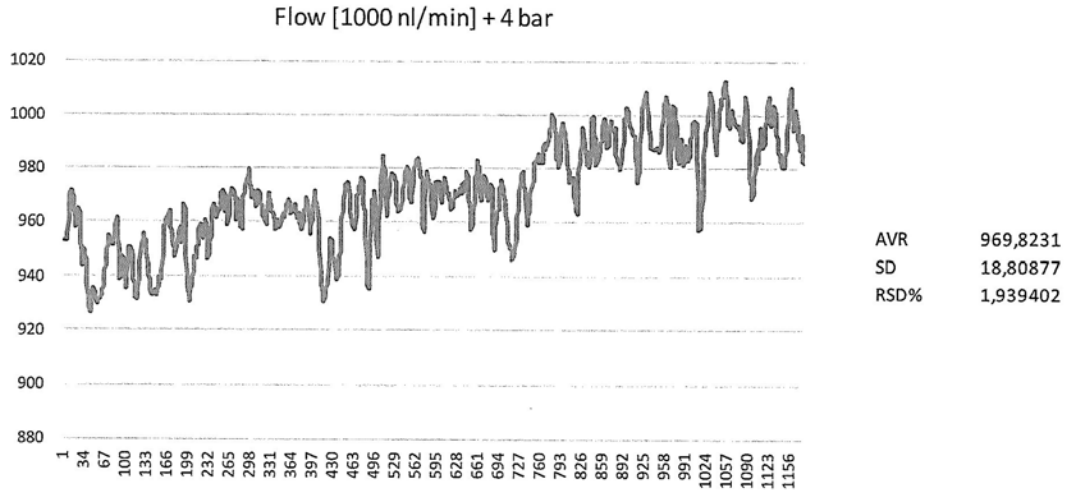

Competitor #2

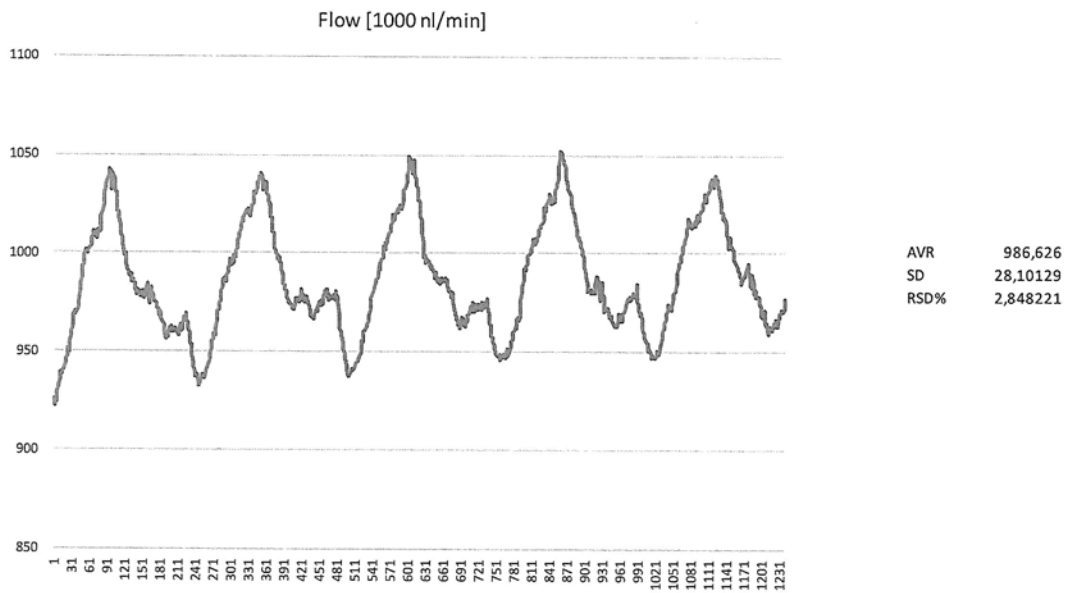

Specifications

Motor Description:

NEMA 17 triple stack step motor - pump controller with motor drive & controller

Power:

100 - 240 VAC, 50 - 60 Hz, 1 A Max

OEM Power Option:

24 VDC, 3A Max

Operating Temperature:

4 - 40° C

Dimensions:

13.75" L x 3" W x 4.1" H (with cover)

OEM Inquiries are welcome!

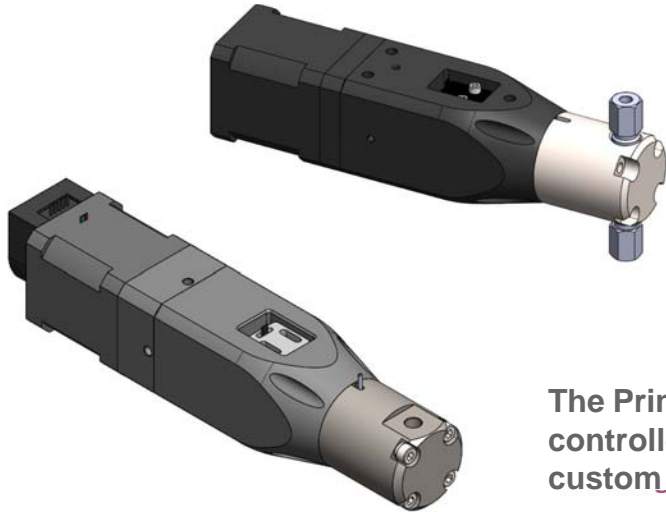

Standard Check Valve Configuration

Single Port and Encoder options

The PrimeLine Syringe Pump without integral drive/controller for stepper motor, check valves or other custom features are available, please contact us.

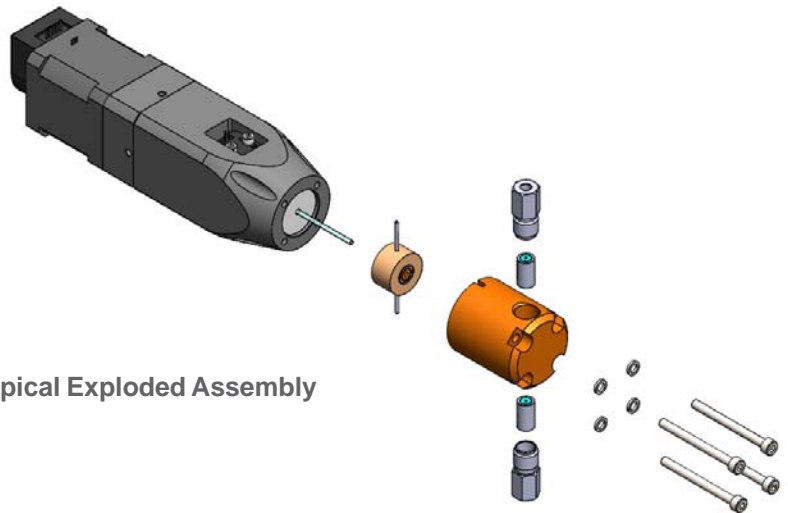

Typical Exploded Assembly



**BIOTECH
FLUIDICS**

Distributor in Europe:
Biotech Fluidics AB, Sweden
info@biotechfluidics.com
www.biotechfluidics.com

Distributor in USA:
Biotech Fluidics LLC, MN
sales@biotechfluidics.com
www.biotechfluidics.com

ASI Analytical Scientific Instruments US